

Sensitivity enhancement of Quantum Design dc superconducting quantum interference devices in two-stage configuration ¹

R. Mezzena¹, A. Vinante¹, P. Falferi², S. Vitale¹, M. Bonaldi², G.A. Prodi¹, M. Cerdonio³,
M.B. Simmonds⁴

1) Dipartimento di Fisica Università di Trento and INFN Gruppo Collegato di Trento, Sezione di Padova, I-38050 Povo - Trento - ITALY.

2) Centro di Fisica degli Stati Aggregati CNR - ITC and INFN Gruppo Collegato di Trento, Sezione di Padova, I-38050 Povo - Trento - ITALY

3) Dipartimento di Fisica Università di Padova and INFN Sezione di Padova, via Marzolo 8, I-35131 Padova - ITALY.

4) Quantum Design, Mammoth Lakes, CA 93546 - USA

Abstract. The energy sensitivity of a direct current (dc) superconducting quantum interference device (SQUID) can be improved if it is operated in a two-stage configuration. Employing this technique, a commercial dc SQUID system was modified and made competitive with other sensors especially designed for very low noise applications. We report the noise measurements performed in the temperature range 4.2 K - 25mK. At 4.2 K, the coupled energy sensitivity obtained with the two-stage dc SQUID was approximately ten times better than with a conventional readout electronics. The noise energy decreases linearly until approximately 300 mK, in good agreement with theoretical previsions. At lower temperature the hot-electron effect produces a saturation and the best energy sensitivity measured with open input coil is $35 \hbar$.

¹Published on Rev. Sci. Instrum. **72**, 3694 (2001)

1. Introduction

Conventional readout electronics do not permit the operation of a direct current (dc) superconducting quantum interference device (SQUID) at noise levels approaching its quantum limit. The noise contribution of the room temperature FET amplifier is dominant and only a very small improvement in the total noise is obtainable lowering the temperature of the dc SQUID sensor below 4.2 K¹. To overcome the problem, a two-stage configuration is usually employed, in which a first SQUID operates as a sensor and a second as an amplifier. Several authors²⁻⁸ have realized double SQUID systems and some were able to obtain near quantum limited energy sensitivity. In the field of gravitational waves detection, where SQUIDs are used as a first stage amplifier of the motion transducer,^{8,9} the proposed very low noise systems^{4,5,8} have to meet special requirements¹ and are still under development.

The two-stage SQUID system described in this article was developed for the AURIGA¹⁰ gravitational wave detector. We decided to build this system employing SQUID sensors and read-out electronics manufactured by Quantum Design (Q.D.),¹¹ motivated by previous experience with such devices. In fact, the AURIGA detector was operated for 3 years with a conventional Q.D. dc SQUID obtaining an effective temperature $T_{eff} \simeq 1$ mK. T_{eff} multiplied by the Boltzmann's constant is the minimum energy detectable by the detector and this 1 mK level is the best obtained with a resonant bar¹². The reliability of the SQUID system was satisfactory and its energy sensitivity was quite close to the specifications, i.e. approximately $4000 \hbar$. Important features of the Q.D. dc SQUID, as amplifier in resonant gravitational waves detectors, are a reasonable value of input coil inductance $\simeq 1.6 \mu\text{H}$ and a quite good coupling factor $k^2 \simeq 0.87$ with the SQUID loop. Also the gradiometric configuration of the input and the feedback coil is a necessary requirement since it strongly reduces the inductive coupling between the two coils and consequently prevents SQUID drive signals from coupling¹³ into the resonant transducer. Moreover, other parameters such as the dynamic input impedance¹⁴, the back action noise contribution¹⁵, and the stability of the Q.D. dc SQUID operated with high Q resonant sources have been characterized in experiments

collateral to the gravitational wave detector operation. The knowledge of this data has been important to optimize the performance of the detector and constitutes a precious resource to invest in further progress. An improvement of the detector sensitivity is in fact strongly desirable since the present one makes it possible only the detection of gravitational waves coming from galactic sources, which have a very low statistical occurrence. According to the Giffard limit¹⁶, if an optimal matching between the amplifier and the detector is achieved, the expected detector best effective noise temperature is $T_{eff} = 2T_{na}$, where T_{na} is the first stage amplifier noise temperature. For a dc SQUID, operated with the theoretical¹⁷ noise level, T_{na} can be related to the noise energy per unit bandwidth ϵ_n by the approximated expression $T_{na} \simeq \omega\epsilon_n/k_B$ where k_B is the Boltzmann constant and ω the angular frequency of the operating signal. A dc SQUID with the lowest noise temperature is therefore necessary to approach the highest detector sensitivity.

2. System description

The schematic of the two-stage SQUID circuit is shown in Fig. 1. The sensor SQUID is current biased by means of a $150\text{ K}\Omega$ resistor which converts the battery voltage into current. The resistor $R_m = 2.3\ \Omega$ in series with a coil $L_{flt} = 15\ \mu\text{H}$ connects the sensor SQUID output with the amplifier SQUID input coil. The R_m value provides a gain of approximately 70 between the two SQUIDs and produces a negligible thermal noise. The L_{flt} coil reduces the interference at the Josephson frequencies between the two SQUIDs and filters the high frequency white noise which would appear as low frequency noise at the output of the amplifier SQUID read out electronics, due to the mixing-down effects¹⁸ of the modulation circuit. Actually, the amplifier SQUID is readout by a conventional Q.D. electronics (Model 550) which operates with a 500 kHz modulation frequency.

When the overall system works in open loop mode, the Q.D. electronics is set in closed loop mode, and operates as a linear amplifier. For closed loop operation of the overall system, the Q.D. electronics operates in open loop mode. In this case the detector output is sent to a one pole low pass filter, with a rolloff frequency of 30 Hz, which acts as an integrator. A 1

$M\Omega$ feedback resistor closes the loop on the sensor SQUID feedback coil.

The sensor and amplifier SQUIDs have standard Q.D. chips. They are fabricated from sputter-deposited niobium using plasma etching to define the features. Superconducting layers are insulated by films of sputter-deposited SiO_2 . The junctions are fabricated using the standard Nb-Al- Al_2O_3 -Al-Nb tri-layer recipe¹⁹. The unique feature of the Q.D. device is its high degree of symmetry. The input and modulation coils are configured as first order gradiometers. The geometry results in "zero" mutual inductance between modulation and input coils. The bias current is introduced into the junctions using four leads in such a way that this current does not couple to either set of coils. The Q.D. SQUID is conceptually similar to a "double balanced mixer" in that the ports are carefully designed to have low cross-coupling. While this approach results in a higher noise level than the classic "Kitchen Washer" it makes the device more suitable for an optimized system design.

The conventional Q.D. assembly was maintained for the amplifier SQUID, while some changes have been made for the sensor SQUID. The toroidal transformer, the heater and the ten pin Lemo connector have been removed from the circuit board on which the chip is mounted. This circuit board was installed in an especially manufactured Nb shield which improves the thermal sink of the chip for the operation in the dilution refrigerator. A thin lead tube running between the two SQUIDs holders contains the twisted-pair wires which connect the sensor SQUID output with the amplifier SQUID input coil.

The wiring connecting the low temperature devices and the room temperature electronics consists of twisted-pair phosphor bronze wires. Two different overbraids enclose separately the sensor and the amplifier SQUID wiring in order to avoid interferences and cross-talk. For the measurements carried out in the dilution refrigerator, the wiring has heat sinks at three different stages: at the 1K pot, at the cold plate and at the mixing chamber. For the amplifier SQUID wiring, we adopted heat sinks which we realized for previous experiments with a conventional single Q.D. SQUID; they are similar to those described in ref.¹. For the sensor SQUID wiring, heat sinks consist of more conventional oxygen-free high-conductivity copper bobbins wrapped with the overbraid. The heat input was minimized, using stainless

steel overbraid for the segment linking the vacuum feedthrough on the top flange with the mixing chamber; copper overbraid and copper twisted-pairs were employed for the segment between the mixing chamber and the SQUID Nb shield, in order to improve the cooling of the sensors.

The dilution refrigerator employed for the experiment is an Oxford Instrument with 200 μ W of cooling power at 100 mK.

Regarding the thermometry, a germanium resistor anchored on the mixing chamber was employed in the dilution refrigerator. Moreover, in order to check the existence of the thermal equilibrium between the sensor SQUID and the mixing chamber, the thermal noise of the matching resistor R_m , which was soldered very close to the sensor SQUID chip on the board inside the Nb shield, was sampled. This was accomplished turning off the bias current of the sensor SQUID and measuring the noise current of R_m by means of the amplifier SQUID. The temperature derived from the Johnson noise formula was compared to the temperature measured with the germanium resistor.

3. Experimental results and discussion

The two-stage SQUID system noise performance was measured in a liquid helium bath in the temperature range 4.2 - 1.2 K and then in a dilution refrigerator down to 25 mK. The sensor SQUID was operated with different input coil configurations : open, shorted and loaded. The system was operated in closed loop with a frequency bandwidth of approximately 15 kHz and flat response up to approximately 6 kHz. At every temperature point, the bias current and the dc flux were properly set in order to obtain the minimum noise. The flux noise spectrum was sampled and the coupled energy sensitivity was computed in the nearly white region between 4 and 6 kHz, and at 1 kHz, which is the typical operation frequency of resonant bar detector for gravitational waves. The coupled energy sensitivity ϵ_n of the SQUID is given by

:

$$\epsilon_n = \frac{L_{in1}\Phi_n^2}{2M^2} \quad (1)$$

where $L_{in1} = 1.63 \mu\text{H}$ is the input coil inductance, Φ_n is the flux noise, and $M = 10.7 \text{ nH}$ is the mutual inductance between the input coil and the SQUID loop. In Fig. 2, ϵ_n is reported with open input coil as a function of the temperature. If the measured noise were due to the thermal noise produced by the SQUID loop shunt resistors R_s , we would expect a temperature dependence in agreement with the Tesche-Clarke formula^{20,21}:

$$\epsilon_n = \frac{(9 \pm 1)k_B T L}{k^2 R_s} \quad (2)$$

where k is the coupling coefficient of M , L is the SQUID loop inductance, and T is the temperature. The experimental data are linear down to approximately 300 mK and then the noise saturates. A linear fit including only the data in the 4.2 - 0.3 K range gives the result $\epsilon_n[\hbar] = (91 \pm 1)T[K] + 14 \pm 2$. The small but not negligible intercept means that a nonthermal contribution to the total noise is present. We will discuss later the possible sources of this additional noise and we examine again the data in the whole explored temperature range. The saturating behavior below 300 mK can be due to a temperature difference between the SQUID and the dilution refrigerator mixing chamber. More precisely, we believe that the Nb shield and the SQUID board were in good thermal equilibrium with the mixing chamber, since the temperature of the germanium resistor was in good agreement with that derived from the Johnson noise of the R_m resistor soldered on the SQUID board. The likely cause of the temperature difference is the hot-electron effect. According to Ref. 3 the electrical power P dissipated by the resistive shunts of the SQUID Josephson junctions is such that the electrons are no longer in thermal equilibrium with phonons at millikelvin temperatures, and the expected effective SQUID temperature T_e is:

$$T_e = \left(\frac{P}{\Sigma \Omega} + T^5 \right)^{1/5} \quad (3)$$

where Σ is a term proportional to the heat capacity and Ω is the shunt resistor volume. Therefore the functional form which should be consistent with the experimental data is

$$\epsilon_n = \frac{9k_B L}{k^2 R_s} \left(T_{min}^5 + T^5 \right)^{1/5} + \epsilon_0 \quad (4)$$

where $T_{min} = [P/(\Sigma\Omega)]^{1/5}$ is the minimum temperature to which the electrons in the SQUID can cool and ϵ_0 is the nonthermal noise contribution. The function (4) was fitted to the experimental data using three parameters: $L/(k^2R_s)$, T_{min} , and ϵ_0 . The results are $L/(k^2R_s) = 7.76 \pm 0.06 \times 10^{-11}$ s, $T_{min} = 0.25 \pm 0.02$ K, and $\epsilon_0 = 13 \pm 2 \hbar$. If we calculate $L/(k^2R_s)$ using the typical data furnished by Q.D. , i.e. $L \simeq 80$ pH, $k^2 \simeq 0.87$, and $R_s \simeq 2 \Omega$, we find agreement within a factor 1.7. The small departure between the experimental and the manufacturer estimated parameters can be due to the thermal noise contribution of some nonsuperconductive metallic part contained inside the SQUID shield. We had evidence of such an effect with a preliminary assembly of the sensor SQUID when we placed a thin (35 μm of thickness) copper slab in contact with the fiber glass board holding the SQUID chip. The purpose was to improve the thermal sink, but the result was an increase of approximately 30 % in the flux noise detected with open input coil. The thermal magnetic noise coupled to the SQUID is greater, by approximately 80 % if the input coil is shorted, due to an increase of the sensing area. We have found that also the small brass screws, used to clamp the Nb wire of an external signal coil to the SQUID input coil, gave a not negligible contribution to the thermal noise. The substitution of such screws with Nb screws improved the flux noise by approximately 15 %. A theoretical approach to the magnetic noise due to the thermal agitation of electric charge in conductors can be found in Refs. 22 and 23.

The results of the noise measurements with the sensor SQUID operated with shorted input coil are reported in Fig. 3. We can observe that the data in the range 4.2 - 3.8 K have a different slope than the data in the range below 3.7 K. This can be attributed to the superconductive transition of the tin solder (96 % tin, 4 % silver) employed on the SQUID circuit board . Above 3.7 K such material is normal and can contribute to the thermal magnetic noise, while below 3.7 K the noise must disappear. The slope of the data below 3.7 K is $37.7 \pm 0.5 \hbar/\text{K}$: compared to the slope of the data sampled with open input coil, is approximately 2.4 times smaller. This fact can be explained by considering the presence of a parasitic capacitance between the input coil and the SQUID loop which modifies the dynamics of the coupled SQUID. According to the theory^{17,24} describing the behavior of a dc

SQUID coupled to an input circuit, it is possible to find an analytical solution in two limiting cases. In the first case the parasitic capacitance is negligible and the SQUID output noise is independent on the value of the inductive input load; in this case, the expected open input noise is equal to the expected shorted input noise. In the second limiting case, the dominant interacting mechanism between input coil and SQUID loop, at the Josephson frequency, is the parasitic capacitance instead of the mutual inductance. In this case, no current flows, at the Josephson frequency, in the input circuit. As a consequence of this assumption, the expected open input noise is approximately 3.5 times higher than the expected shorted input noise. Our experimental result is not very far from this prediction and therefore can confirm the existence of a not negligible parasitic capacitance between the input coil and the SQUID loop.

Regarding the noise performance of the system with loaded input coil, we can report a measurement at the temperature 4.2 K with a 2 μH coil connected to the input of the sensor SQUID. The coil was housed in a Nb shield separated from that of the sensor SQUID in order to avoid the pick up of the thermal noise produced by that metallic parts (like circuit board traces) present on the SQUID board, which we could not remove. We have found a value of flux noise intermediate between the shorted and the open input coil configuration, corresponding to a noise energy of 244 \hbar , in the nearly white region.

As previously stated, we have reported the energy sensitivity calculated in the frequency range 4-6 kHz, where we have found a nearly flat flux spectrum. However, if we look at Fig. 4, we can note that at 0.1 K the 1/f contribution to the total noise, is not negligible. A dependence of the 1/f noise on the temperature is not evident in our measurements and therefore we have estimated a mean value for the explored temperature range which corresponds to approximately 5 \hbar at 5 kHz. With this correction, the temperature independent noise ϵ_0 expected by Eq.(4) has to be reduced to approximately 8 \hbar . Another part of ϵ_0 is also due to the current noise generated by the room temperature resistors directly connected to the SQUID and by the readout electronics of the amplifier SQUID. The 1 M Ω feedback resistor contributes approximately 2 \hbar , the bias resistor less than 0.5 \hbar , and the readout electronics

approximately $0.5 \hbar$. Finally we attribute the remaining $5 \hbar$ to EMI; this is reasonably small value and gives an estimation of the efficiency of shielding and filtering of the system.

To complete the list of the noise sources which are external to the sensor SQUID, we must include the contribution of the matching resistor R_m . This noise scales with the temperature, and we estimated that contributes less than 10 % to the noise energy.

Applications which require high energy sensitivity can greatly benefit from this system, and, in particular, it is very promising in the gravitational wave detection field. For the Auriga detector, the employment of this two-stage SQUID amplifier would improve the energy sensitivity by nearly two order of magnitude. A somehow better result could be obtained if it were possible to decrease the $1/f$ noise cut off frequency. Unfortunately the conventional modulation scheme, which is usually employed to reduce $1/f$ noise, seems quite difficult to implement due to the limited SQUID amplifier bandwidth and dynamic range, and, moreover it could be difficult to maintain a good noise insulation of the sensor SQUID if additional modulating signals have to be added.

Further experiments are in progress in order to measure the back action noise by means of a high quality factor resonator coupled to the two-stage SQUID system.

Acknowledgments

This work has been supported in part by a grant MURST-COFIN 1999 and by INFN. The authors are indebted to our colleague of the Auriga Collaboration for stimulating our interest in this work. The authors would like to thank W. Zoeckler and S. Brando for helping to establish the collaboration with Quantum Design.

References

- ¹Z.K. Geng, P.W. Adams, W.O. Hamilton, W.W. Johnson and N.D. Solomonson, Rev. Sci. Instrum., **64**(5), 1319 (1993)
- ²D.D. Awschalom, J.R. Rozen, M.B. Ketchen, W.J. Gallagher, A.W. Kleinsasser, R.L. Sandstrom, and B. Bumble, Appl. Phys. Lett. **53** 2108 (1988)
- ³F.C. Wellstood, C. Urbina and J. Clarke, Phys. Rev. B, **49**(9), 5942 (1994)
- ⁴I. Jin, A. Amar, T.R. Stevenson, F.C. Wellstood, A. Morse, W.W. Johnson IEEE Trans. Appl. Super. **7**(2) 2742, (1997)
- ⁵P. Carelli, M.G. Castellano, G. Torrioli and R. Leoni, Appl. Phys. Lett. **72** 115 (1998)
- ⁶D.E. Kirichenko, A.B. Pavolotskij, I.G. Prokhorova, O.V. Snigirev, R. Mezzena, S. Vitale, Y.V. Maslennikov and A.V. Beljaev, IEEE Trans. Appl. Super. **9**(2) 2906, (1999)
- ⁷M. Podt, M.J. van Duuren, A. W. Hamster, J. Flokstra and H. Rogalla, Appl. Phys. Lett. **75** 2316 (1999)
- ⁸G.M. Harry, I. Jin, H.J. Paik, T.R. Stevenson, F.C. Wellstood, Appl. Phys. Lett. **76**(11) 1446, (2000)
- ⁹C. Cinquegrana, E. Majorana, P. Rapagnani and F. Ricci, Phys. Rev. D **48**, 448 (1993)
- ¹⁰M. Cerdonio, M. Bonaldi, D.Carlesso, E. Cavallini, S. Caruso, A. Colombo, P. Falferi , G. Fontana, P.L. Fortini, R. Mezzena, A. Ortolan, G.A. Prodi, L. Taffarello, G. Vedovato, S. Vitale and J.P. Zendri Class. Quantum Grav. **14**(6) 1491, (1997)
- ¹¹Quantum Design, 11578 Sorrento Valley Road, Suite 30, San Diego, CA 92121
- ¹²J. P. Zendri, L. Baggio, M. Bonaldi, M. Cerdonio, L. Conti, V. Crivelli Visconti, P. Falferi, P. Fortini, V. Martinucci, R. Mezzena, A. Ortolan, G.A. Prodi, G. Soranzo, L. Taffarello, G. Vedovato, A. Vinante and S. Vitale , *in proceeding of the "Third Edoardo Amaldi Conference"* AIP Conf. Proc. **523** 421 (2000)
- ¹³W.M. Folkner, M.V. Moody, J.P. Richard, K.R. Carroll and C.D. Tesche, J. Appl. Phys. **65**,5190 (1989)
- ¹⁴P. Falferi, R. Mezzena, S. Vitale and M. Cerdonio, Appl. Phys. Lett. **71**(7) 956 (1997)
- ¹⁵P. Falferi, M. Bonaldi, M. Cerdonio, A. Vinante and S. Vitale, Appl. Phys. Lett. **73**, 3589

(1998)

¹⁶R.P. Giffard, Phys. Rev. **D 14**, 2478 (1976)

¹⁷J. Martinis and J. Clarke, J. Low Temp. Phys. **61** 227 (1985)

¹⁸J. Knuutila, A. Ahonen, C. Tesche, J. Low Temp. Phys. **68** 269 (1987)

¹⁹M. Gurvitch, M.A. Washington, and H.A. Huggins, Appl. Phys. Lett. **42**, 472 (1983)

²⁰C. Tesche and J. Clarke, J. Low Temp. Phys. **29** 301 (1977)

²¹J.J.P. Bruines, V.J. de Waal, and J.E. Mooij, J. Low Temp. Phys. **46** 383 (1982)

²²T. Varpula and T. Poutanen, J. Appl. Phys. **55**(11), 4015 (1984)

²³J. R. Clem, IEEE Trans. Mag., **MAG-23**(2), 1093 (1987)

²⁴P. Falferi, M. Bonaldi, M. Cerdonio, M. Mück, A. Vinante, R. Mezzena, G. A. Prodi, S. Vitale, J. Low Temp. Phys. **123**, 275 (2001)

Figure Captions

Fig. 1. Schematic circuit diagram of the two-stage SQUID system.

Fig. 2. The coupled energy sensitivity of the system with open input coil as a function of the temperature; the circles and the squares represent respectively the energy noise in the nearly white noise region and at approximately 1 kHz. The solid line is a three parameters fitting of the function Eq.(4) to the data

Fig. 3. The coupled energy sensitivity of the system with shorted input coil as a function of the temperature; the circles and the squares represent respectively the energy noise in the nearly white noise region and at approximately 1 kHz. The solid line is a linear fit to the data.

Fig. 4. The flux noise spectrum of the system with open input coil at 4.1 K and 0.1 K.

Figure 1 – R. Mezzena – Rev. Sci. Instrum.

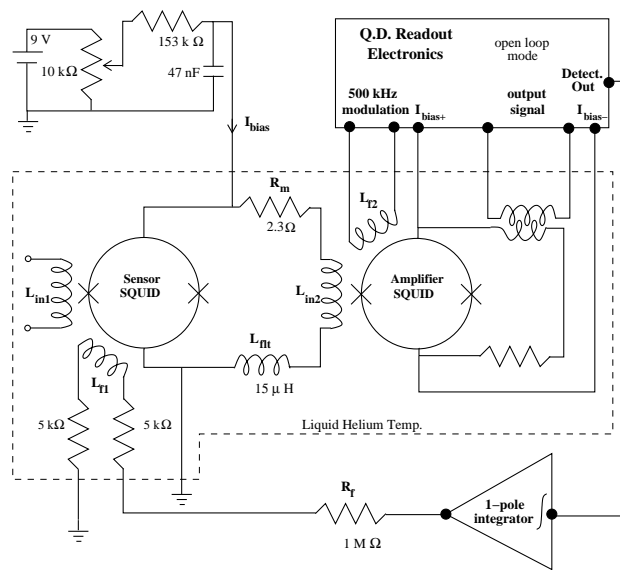

Figure 2 - R. Mezzena - Rev. Sci. Instrum.

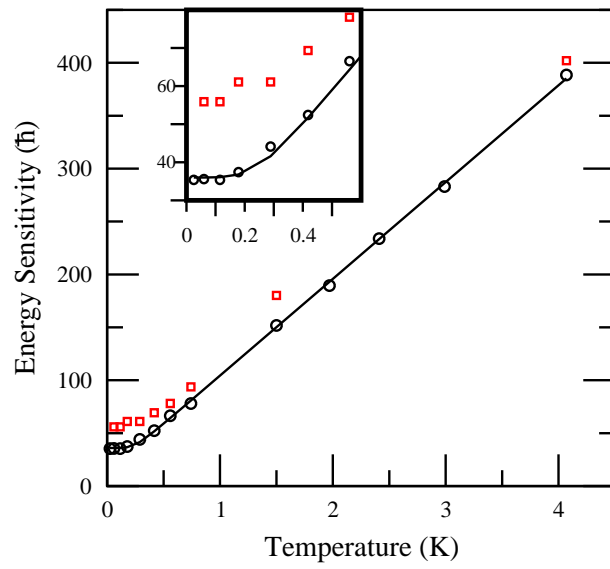

Figure 3 - R. Mezzena - Rev. Sci. Instrum.

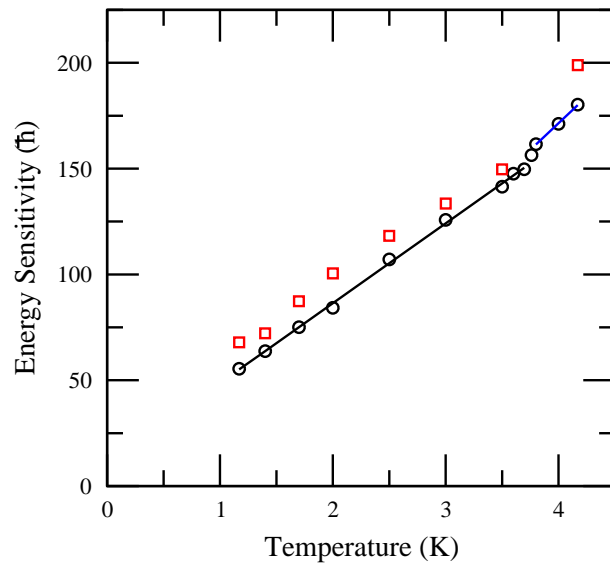

Figure 4 - R. Mezzena - Rev. Sci. Instrum.

